

Theory and Design

Dual-Wavelength Optoelectronic Sensor for Monitoring Uric Acid Concentration in Dialysate

A. M. Vasilevsky^{1*}, R. P. Gerasimchuk², A. Yu. Zemchenkov², G. A. Konoplev¹, A. V. Rubinsky³, O. S. Stepanova¹, and A. A. Frorip⁴

Existing methods and instruments for online monitoring of the hemodialysis procedure, a method for determining the concentration of uric acid in dialysate by the level of spectral absorption at two wavelengths in the ultraviolet region of the spectrum, the main characteristics and block diagram of an optoelectronic sensor based on a UV-LED monitoring of the concentration of uric acid in the dialysis line of an “artificial kidney” apparatus, and analysis of results of clinical trials of the developed sensor are described.

Hemodialysis (HD) is a procedure of extracorporeal blood purification of patients suffering from chronic renal failure (CRF) from low molecular weight metabolic products and excess water. The procedure is performed using an “artificial kidney” (AK) apparatus [1].

Modern AK apparatuses have a developed control system of many parameters (temperature and pressure in the lines, blood and dialysate flow velocity, osmolality and conductivity of the dialysate, volume of ultrafiltration, transmembrane pressure, etc.) ensuring patient safety in different modes of the HD procedure. For rapid assessment of effectiveness during the course of a HD session, the concentration of one or more marker substances (markers of uremia) should be monitored in the dialysate flowing in the dialysis line of the AK apparatus. Practical implementation of monitoring of these parameters requires special systems.

There are three main types of monitoring systems of dialysate composition: systems based on electrochemical sensors of urea, conductivity measuring systems, and optoelectronic systems. The optoelectronic systems are based on the online measurement of the UV spectral transmittance of the dialysate at one or more wavelengths [2-6]. Such systems include a flow cell, which is connected to the output of the dialysis line and a source and receiver of radiation. Optoelectronic systems have several advantages over devices based on electrochemical and conductivity sensors because they allow simultaneous concentration determination for several dialysate components, do not require the use of consumable products, and do not contain complex mechanical or hydraulic modules. In recent years, light-emitting diodes were created on the basis of semiconductor compounds such as AlGaIn emitting in the spectral range of 240-350 nm, which can be used for development of miniaturized spectral sensors, eliminating the need for expensive equipment. A relative disadvantage of optoelectronic systems is their inability to monitor concentration of urea, which has no characteristic absorption bands in the measurable spectrum.

The aim of this work was to study and develop a dual-wavelength optoelectronic sensor for monitoring the HD

¹ St. Petersburg State Electrotechnical University (LETI), St. Petersburg, Russia; E-mail: amvasilevsky@mail.ru

² Mariinsky City Hospital, St. Petersburg, Russia.

³ First Pavlov State Medical University of St. Petersburg, St. Petersburg, Russia.

⁴ LDIAMON AS, Tartu, Estonia.

* To whom correspondence should be addressed.

procedure by uric acid concentrations, based on online analysis of spectral absorption of the flowing dialysate in two quasi-monochromatic regions of the UV spectrum.

Uric acid is one of the main low molecular weight uremic toxins and has noticeable absorption in the wavelength region of 285–295 nm ($\lambda_{\max} = 290$ nm). The substance accumulates in the body of patients with CRF and is removed during the HD procedure, so changing concentration of uric acid in flowing off dialysate provides objective information on the effectiveness of the HD procedure.

Dual-Wavelength Method for Determining Uric Acid Concentration in Dialysate

Long-term (more than 10 years, more than 150 patients) spectral studies of exiting dialysate samples taken at different times during an HD session from the output line of the AK apparatus showed that dynamics of spectral absorption of dialysate in the wavelength range of 260–300 nm (Fig. 1) has close correlation with the dynamics of uric acid concentration [5]. The magnitude of the correlation coefficient and the integral absorbed concentration of dialysate in the wavelength range of 278–302 nm is greater than 0.99, indicating that monitoring the uric acid concentration is possible using UV spectrophotometry.

Based on the results of spectral analysis of dialysate samples and the results of mathematical modeling, the dual-wavelength method for determining the concentration of uric acid was proposed [7], which is based on the

spectral absorption of the dialysate in the 260–300 nm range as the absorption of a two-component medium that includes uric acid and a pseudo-component NK, which is a combination of several identified (hippuric acid, pseudonym of uridine, adenosine) and unidentified components, whose clinical significance is currently not completely defined. Spectral absorption of dialysate in the 285–295-nm region is mainly due to uric acid, assessment of contribution to the absorption of the pseudo-component NK is optimally performed in the region 260–270 nm, where the specific absorption of uric acid is minimal.

The method enables online monitoring of the HD procedures by uric acid concentration using compact and inexpensive equipment based on UV-LEDs emitting in narrow (quasi-monochromatic) spectral regions 295–285 and 260–270 nm. Characteristics of modern UV-LEDs remove the need for additional monochromatization of radiation.

Dual-Wavelength Optoelectronic Sensor

The developed sensor provides automated measurement of transmission coefficients of the dialysis fluid in the dialysis line of the AK apparatus in narrow spectral intervals near the wavelengths of 262 and 287 nm. The sensor is manufactured by LDIAMON AS (Estonia).

The device comprises an optical module (Fig. 2) including radiation sources (1) – UV-LEDs with peak emission spectrum at wavelengths 287 and 262 nm; quartz flow cell (3) connected to the dialysis line (9); a “solar-blind” photodetector (4) for registration of UV radiation from the LEDs passing through the cell with the dialysate; power supply of radiation sources (2); electric signal recording and processing module (5) comprising an amplifier and an analog-to-digital converter; control and data processing module (6), module of data exchange with a computer (7); and computer (8).

The sensor works as follows. Radiation of the LEDs (1) is directed to the flow cell (3) connected to the dialysis line of the AK apparatus (9), and the radiation that passes through the cell containing dialysis liquid is focused on the photodetector (4). The registration module (5) amplifies output electric signals from the photodetector and converts them into digital code. The control and data processing module (6) sets the registration mode in the module (5), controls the radiation sources using the module of source power supply (2), records the photodetector signals, saves the data in an internal buffer, and forms and transmits the data to the module of data exchange with a computer (7).

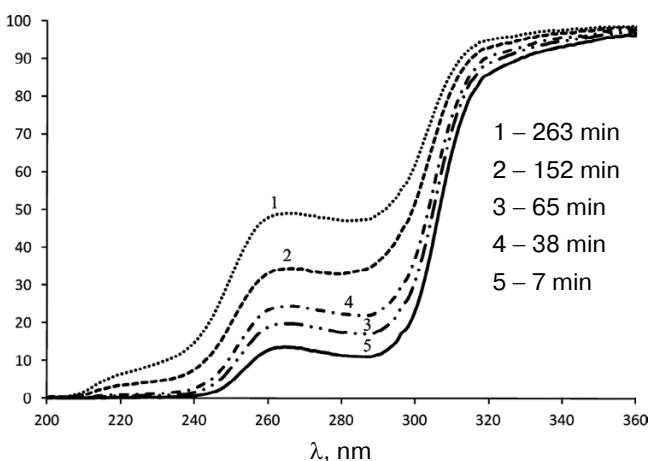

Fig. 1. Transmission spectra of dialysate at different times during an HD session.

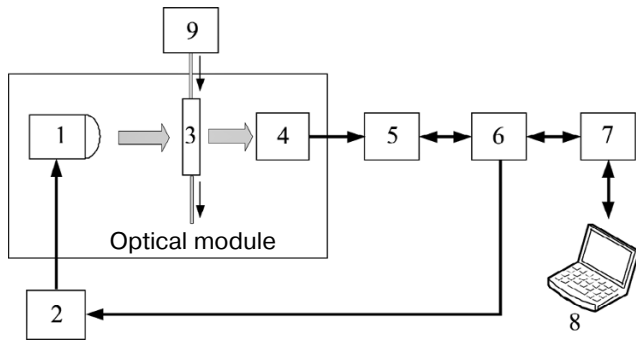

Fig. 2. Block diagram of the dual-wavelength sensor.

The internal program of the microcontroller registers working (radiation sources turned on) and dark (radiation sources turned off) signals of the photodetector with a time interval of 1 s. The values of two respective signals are recorded in the internal information registries of the sensor, from which by an external command they can be read and transferred to the computer via a USB interface. Control of the dual-wavelength sensor, automated online registration of spectral information, calculation of the uric acid concentration in accordance with the developed method, and output of the results of monitoring of an HD session in a form convenient for the medical personnel is implemented using the computer software HDMonitor.

Results of Clinical Trials of the Sensor

Clinical trials of the sensor were conducted in the Department of Hemodialysis of Mariinsky City Hospital of St. Petersburg. Studies were conducted in the course of 23 HD sessions of nine patients. The time dependence of the spectral transmittance of the dialysate and the uric acid concentration for one of the patients received during one of the HD sessions together with the results of biochemical analysis on an Beckman Coulter AU680 automated analyzer are shown in Figs. 3 and 4, respectively.

For statistical analysis of the results of determining uric acid concentration in dialysate samples, the Bland–Altman method was used, allowing comparison of two analytical techniques [8]. Results of statistical analysis indicated good convergence of the data obtained using the sensor and the data of biochemical studies. The correlation coefficient was $R = 0.987$, average value of the absolute error in determining the uric acid concen-

tration – 3.6 $\mu\text{mol/liter}$, mean square error – 6.5 $\mu\text{mol/liter}$.

Next, the developed dual-wavelength method and optoelectronic sensor were used to study the kinetics of elimination of uric acid in the HD procedure for a two-compartment model of distribution of uremic markers within the human body [9]. The advantage of the used methods and equipment to traditional approaches, based on periodic sampling of the patient’s blood for biochemical analysis (at least 5-7 samples per HD session), is

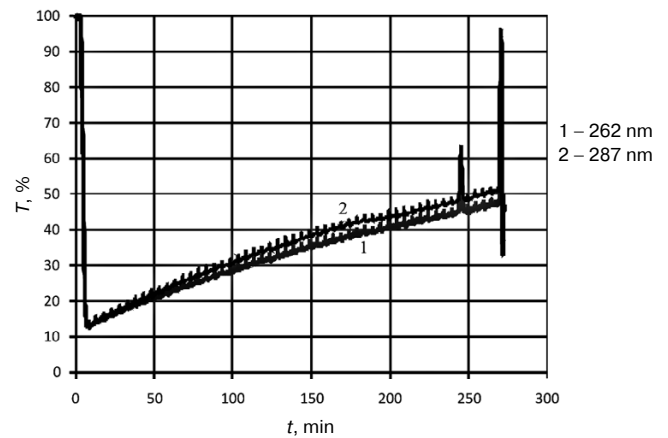

Fig. 3. Spectral transmittance of dialysate in two narrow spectral intervals (central wavelengths 262 and 287 nm) in the course of monitoring of a HD session.

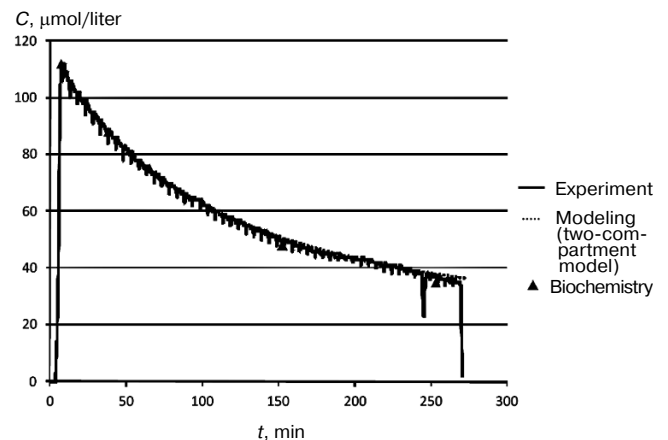

Fig. 4. Time dependence of uric acid concentration in the exiting dialysate calculated according to data of the dual-wavelength sensor, results of modeling (two-compartment model), and data of biochemical analysis of several samples taken in the course of the session.

based on the fact that the sensor provides the time dependence of the uric acid concentration during the HD session with very high time resolution. This made it possible to approximate the curves in accordance with the two-compartment model (Fig. 4) and calculate the time constant of uric acid removal without additional measurements during the time between HD sessions [9].

Thus, the results of clinical trials showed that the error in determining uric acid concentration by the dual-wavelength sensor is comparable to the error in determining the concentration using the Beckman Coulter AU680 biochemical analyzer. Therefore, the developed optoelectronic sensor can be recommended for monitoring HD for both research and clinical practice.

REFERENCES

1. Horl W.H., Koch K.-M., Lindsay R.M., Ronco C., Winchester J.F. (eds.), *Replacement of Renal Function by Dialysis*, 5th Edn., Springer (2004).
2. Daugirdas J.T., Tattersall J.E., *Kidney Int.*, **78**, 833-835 (2010).
3. Fridolin L., Lauri K., Jerotskaja J., Luman M., *Est. J. Eng.*, **14**, No. 2, 177-188 (2008).
4. Umimoto K., Tatsumi Y., Jokei K., *Nephrol. Dial. Transplant.*, **22** (Suppl. 6), VI127 (2007).
5. Vasilevskii A.M., *Inform.-Upravl. Sist.*, No. 1, 40-46 (2003).
6. Vasilevskii A.M., Konoplev G.A., *Biotekhnosfera*, No. 1, 18-25 (2009).
7. Vasilevskii A.M., Konoplev G.A., Lopatenko O.S., et al., *Izv. SPbGETU LETI*, No. 10, 97-104 (2012).
8. Bland J.M., *The Lancet*, No. 8, 307-310 (1986).
9. Burgelman M., Vanholder R., Fostierx H., Ringoir S., *Med. Eng. Phys.*, **19**, 69-76 (1997).